



SYSTEMS S3000

INDUSTRIAL CONTROLLER

S3064: DIGITAL DC INPUT BOARD 16-POINT 10-30VDC SINKING

FEATURES:

- 16 DIGITAL INPUT POINTS
- 2 INDIVIDUALLY ISOLATED SECTIONS OF 8 POINTS EACH
- 16 INDIVIDUAL STATUS LEDs (1 LED PER INPUT POINT)
- REMOVABLE FIELD WIRING CONNECTOR
- INDIVIDUALLY SELECTABLE INPUT FILTER DELAY
- OPTICAL ISOLATION
- STANDARD DOUBLE HEIGHT EUROCARD

GENERAL DESCRIPTION:

The S3064 10-30VDC Input Board contains 16 identical solid state input circuits which accept the on/off status of user devices such as push-buttons, limit switches, and proximity sensors. The inputs sense the voltage levels of digital DC input signals, with the devices driving the inputs being defined as sinking (positive current out of the input). When the voltage at the input is high (approximately equal to the users supply voltage), the input is read as a "0". When the input is low (approximately zero), the input is read as a "1".

The 16 inputs are split into two separate, isolated sections of eight points each. This allows two different user voltage supplies (VCC and COMMON) to be connected to the same input board. The on/off status of each input is indicated with individual LEDs located on the

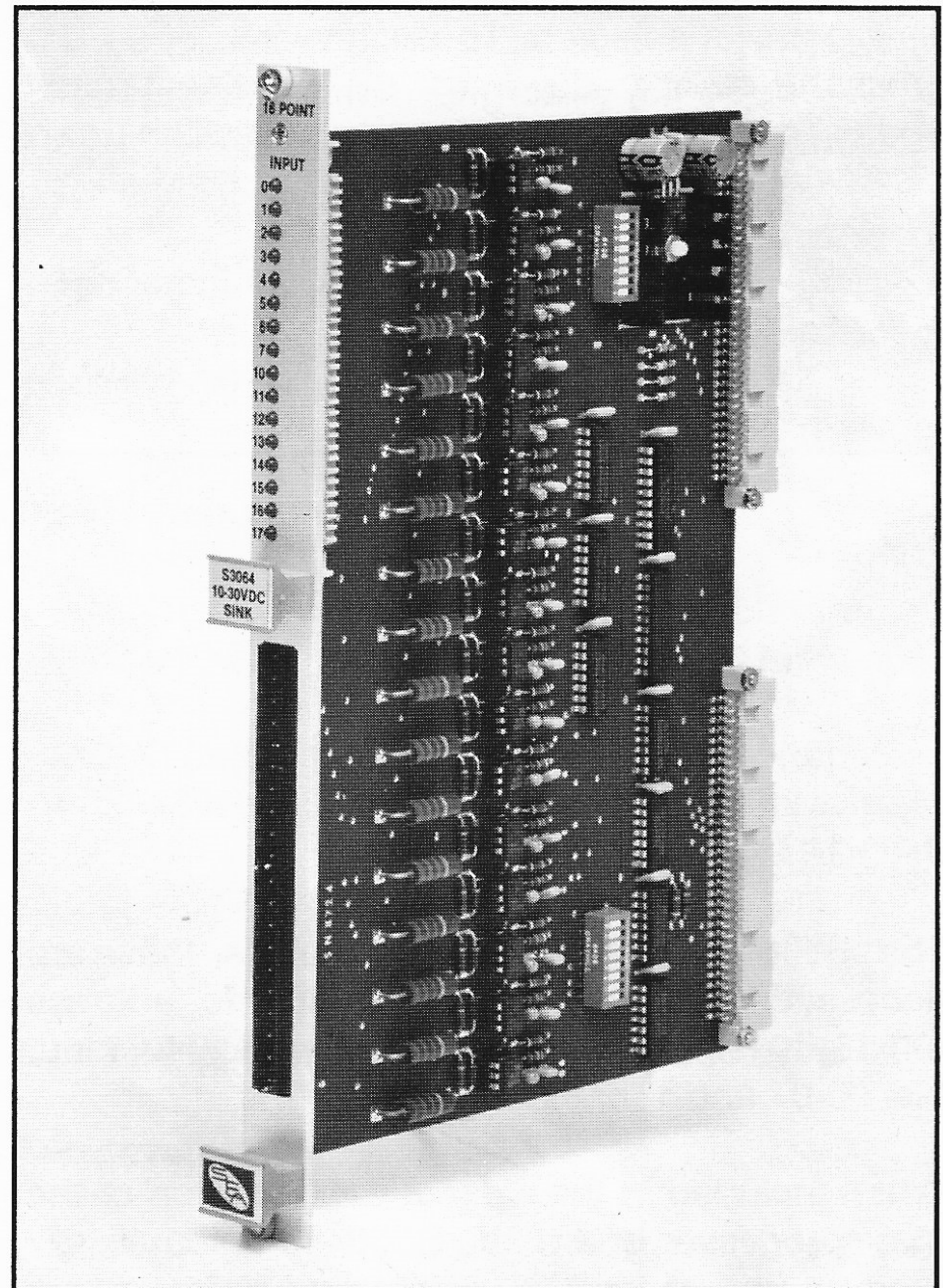

faceplate. The LEDs provide the status of the actual input points (field side) rather than the internal logic status.

Input and user power wiring is implemented with a removable 20-pin field wiring connector which allows easy board replacement. Refer to Figure 2 for typical field wiring connections.

The filter delay of each input can be independently set for either a long or short delay via dip switches mounted on the circuit board. The short filter delay is used when interfacing to proximity sensors or other solid state devices while the long filter delay is used when interfacing to mechanical contact switches such as push-buttons where it is necessary to eliminate contact bounce.

INSTALLATION:

Prior to installing the S3064, the filter delay dip switches should be set to the desired positions. Refer to Figure 1. The switches are arranged in two groups of eight switches each. The first group of switches (Z2), sets the filter delay of inputs 0 through 7. The second group of switches (Z1), sets the filter delay of inputs 10 through 17. When a respective switch is open, the short filter delay is selected. When the switch is closed, the long filter delay is selected. To set a switch open, depress the switch down on the side that reads open. To close a switch, depress the switch down

on the opposite side. The S3064 may be installed in any I/O slot of the S3000 rack. Install the S3064 by aligning the board with the card guides and sliding in until firmly seated. The board is held in the rack via captive screws located on the S3064 faceplate. To remove the S3064, loosen the captive screws and gently pull the board out of the rack using the handles located on the S3064 faceplate.

NOTE: When installing or removing an S3064, the system should be in power-down mode (PS3007 power supply off).

PROGRAM INTERFACE

The S3064 contains two input bytes, these are accessed by specifying the two digit slot address (00-15) plus the one digit byte address (0 for input bits 00-07 and 1 for input bits 10-17).

When included in the system configuration of the main processor board, the S3064 is automatically read as part of the I/O update and mapped to a corresponding Input variable.

The format of this variable is:

Input byte: Xaab
Input bit: Xaab.c

Where: X = input variable type (X)

aa = two digit slot address
(00 - 15)

b = byte address
(0 for inputs 00 - 07,
1 for inputs 10 - 17)

c = bit address (0 - 7)

These variables represent the input status of the S3064 at the last I/O update performed at the beginning of the main program scan.

SPECIFICATIONS:

Number Of I/O Slots Required: 1

Board Size:

Length: 9.15"

Height: 6.30"

Width: 0.80"

Number Of I/O Points: 16

Number Of Isolated Sections: 2

Input Voltage:

Voltage Range: 10 to 30 volts

Vin(on) -minimum guaranteed turn on: 10.0 volts

Vin(off)-maximum guaranteed turnoff: 3.5 volts

Vin(max)-maximum continuous on voltage:
30.0 volts

Vin(pul)-maximum pulsed (10msec): 150.0 volts

Input Current:

Iin(max)-maximum input current (Vin=10v)
6.5 milliamps

Iin(max)-maximum input current (Vin=30v)
24.0 milliamps

Input Impedance (approximate): 1.2K ohms

Input Filter Delay:

Tplhs(min)-minimum short delay (off-on):
0.5 millisecc

Tplhs(max)-maximum short delay (off-on):
1.5 millisecc

Tphls(min)-minimum short delay (on-off):
0.6 millisecc

Tphls(max)-maximum short delay (on-off):
2.0 millisecc

Tplhl(min)-minimum long delay (off-on):
5.0 millisecc

Tplhl(max)-maximum long delay (off-on):
12.0 millisecc

Tphll(min)-minimum long delay (on-off):
6.5 millisecc

Tphll(max)-maximum long delay (on-off):
16.0 millisecc

Power Requirements (all inputs on):

IccEXT(max)-maximum users supply current
(Vcc=10v): 110 milliamps

IccEXT(max)-maximum users supply current
(Vcc=30v): 385 milliamps

IccBUS(max)-maximum S3000 bus current:
150 milliamps

Optical Isolation (input to bus): 2500 Vrms

Temperature Ranges:

Storage: 0 to 85° C

Operating: 0 to 60° C

Relative Humidity: 5 To 95%

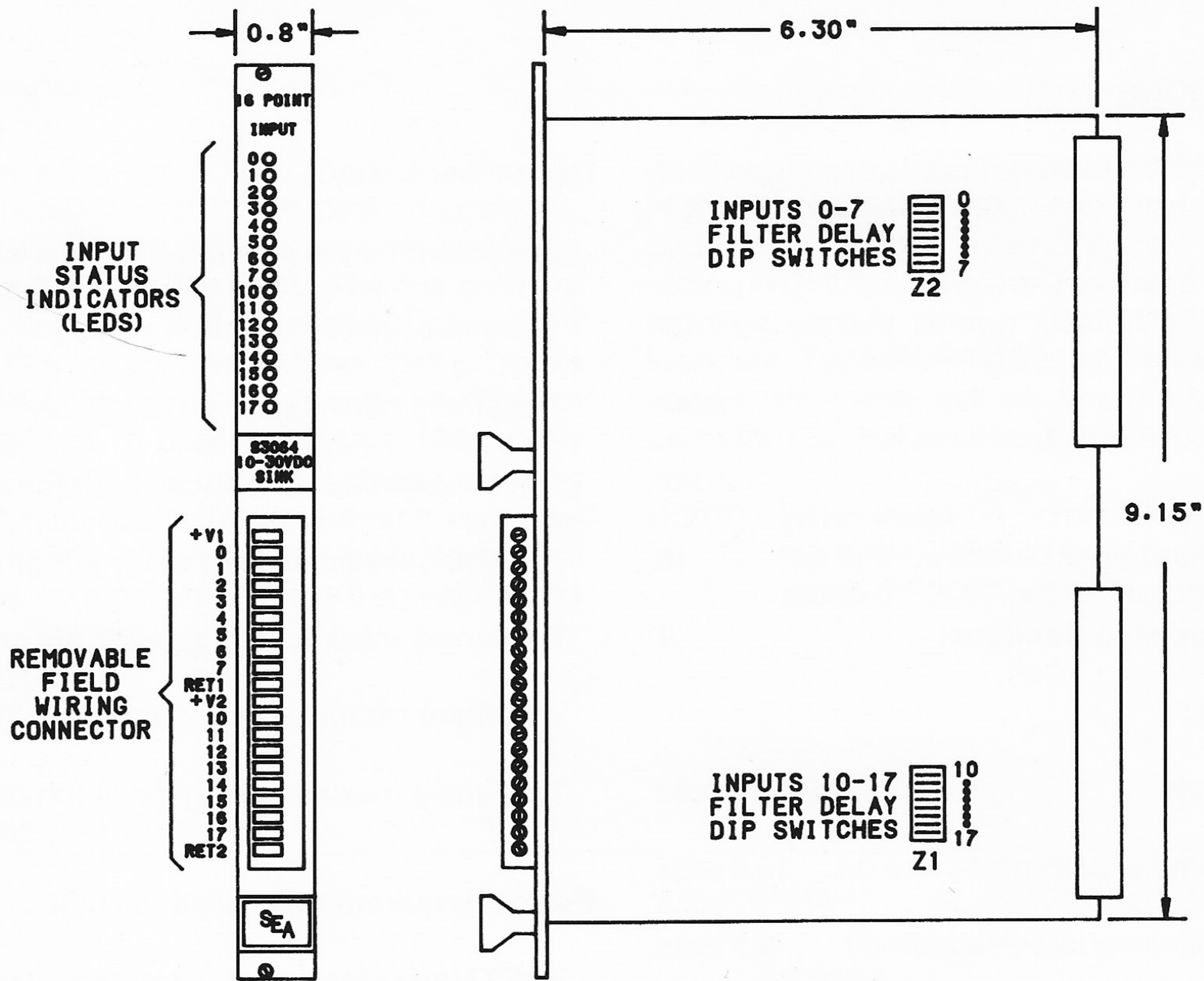

FIGURE 1
BOARD OUTLINE

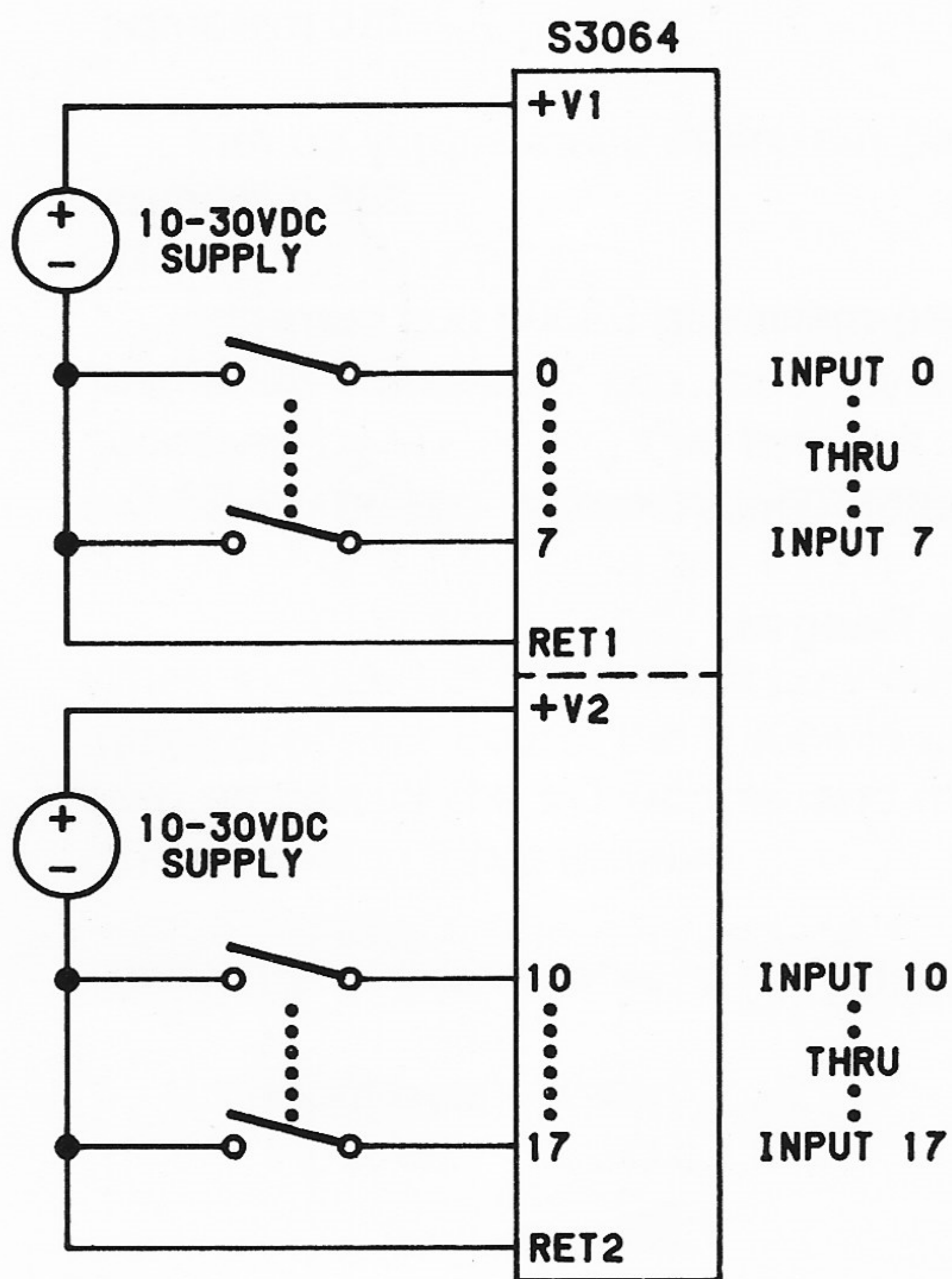

FIGURE 2
TYPICAL USER WIRING

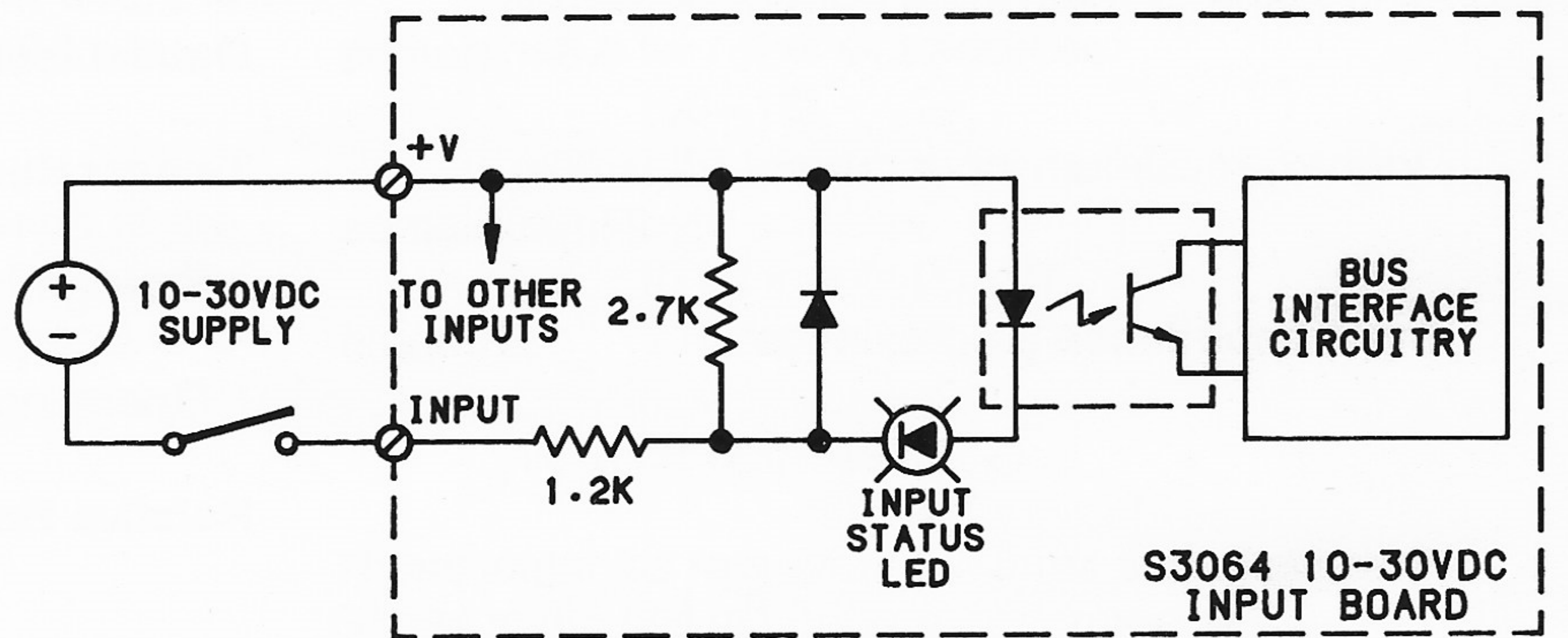

FIGURE 3
TYPICAL INPUT CIRCUIT



SYSTEMS ELECTRONICS GROUP

DIVISION OF SYSTEMS ENGINEERING ASSOCIATES, INC.
14989 W. 69TH AVE, ARVADA, COLORADO, P.O. BOX 750 80001
(303) 421-0233 FAX (303) 421-8108